



Ergomodul

The all-round labeller



 **KRONES**

For all who shoot for the moon



The EM series from the Krones labelling systems offers the perfect machine for every application. It offers three main machines, six table diameters, seven labelling station types – and it offers numerous options for combining the individual elements with each other. The Ergomodul is its technological spearhead: A lean, highly efficient machine for ultra-flexible applications.

At a glance

- High-tech model of the KRONES EM-series
- Columnless machine with interchangeable labelling stations
- Labelling method and speed:
 - Pre-cut labels with cold glue up to 72,000 containers per hour
 - Pre-cut labels with hotmelt up to 72,000 containers per hour
 - Reel-fed labels with hotmelt up to 100,000 containers per hour
 - Self-adhesive reel-fed labels up to 60,000 containers per hour



EM: Ergonomic model

The EM series

All models at a glance



	Pre-cut label application with cold glue	Reel-fed labelling with hotmelt	Pre-cut label application with hotmelt	Reel-fed labelling with self-adhesive labels
Machine with table top	Ergomatic	Contiroll	Canmatic	Autocol
Columnless machine with fixed labelling stations	Ergomatic Pro	–	–	Autocol Pro
Columnless machine with interchangeable labelling stations			Ergomodul	

Technical features



Material

- Table top and machine support made of stainless steel
- Container table made of aluminium
- Option: Container table in stainless steel design

Benefits to you

Rigid design, easy maintenance and long service life



Technical features



Dimensions

- Slim main machine
- Significantly reduced footprint in comparison to other labellers

Benefits to you

- Ease of installation – particularly when replacing existing machines
- Ease of transport and ingress
- Can be easily integrated in all kinds of different lines and hall layout



Technical features



Universal use of servo drives

- Main drive
- Infeed and discharge starwheels
- Infeed worm

Benefits to you

- No lubrication required
- Reduced noise
- High energy efficiency
- No stop starwheel required and therefore fewer handling parts and shorter change-over times
- Increased efficiency through increased coupling speed
- Prepared for condition monitoring
- Electronic overload clutch through torque limiting

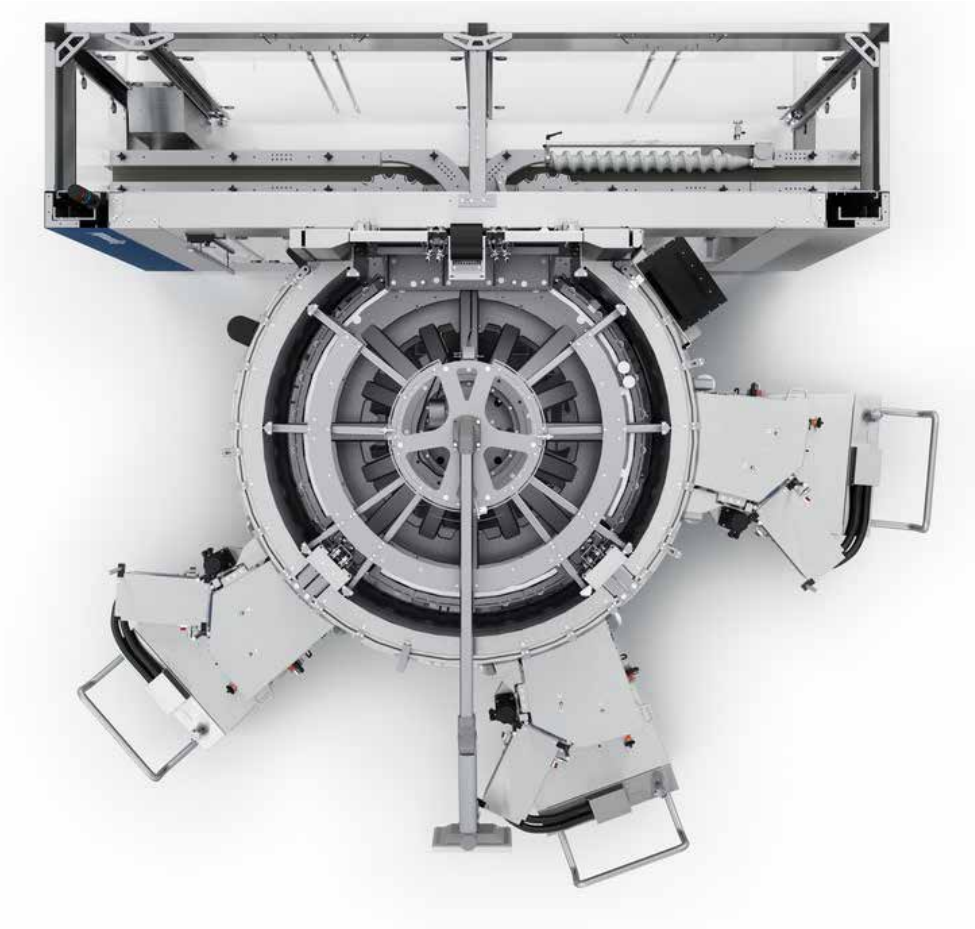

Technical features



Machine design

- Newly designed machine layout with columnless machine guards on the carousel
 - Ergonomic replacement of the brushing-on unit, container plate and centring bells
- Lift-guard with integrated safety switches
- Stand-alone labelling stations
 - Optimal accessibility from three sides
- Hygienic design
 - Optimal cleaning properties

Touch-screen

- Optimal accessibility thanks to height-adjustable pivoting arm
- One single operator panel for the main machine, labelling stations and all PLCs
 - Central saving of all parameters
 - Omission of double infeed avoids faults



Benefits to you

- Reducer complexity as a red thread:
- Top ergonomic design
 - Ease of operation

Technical features



Bottle plate control

- Separately-driven servo motors
- All components are UL certified
- Separate supply ensures easy restart after an EMERGENCY STOP
- Well-arranged visualisation system on the touch-screen
- Processing of subcams possible
- Prepared for condition monitoring
- Complete diagnostic capability thanks to new bus system
- Replacement of the motors according to the "plug-and-play" principle

Benefits to you

- Drive technology of the latest generation
- Significant reduction of the maintenance-relevant downtimes
- Certified safety
- Easy operation

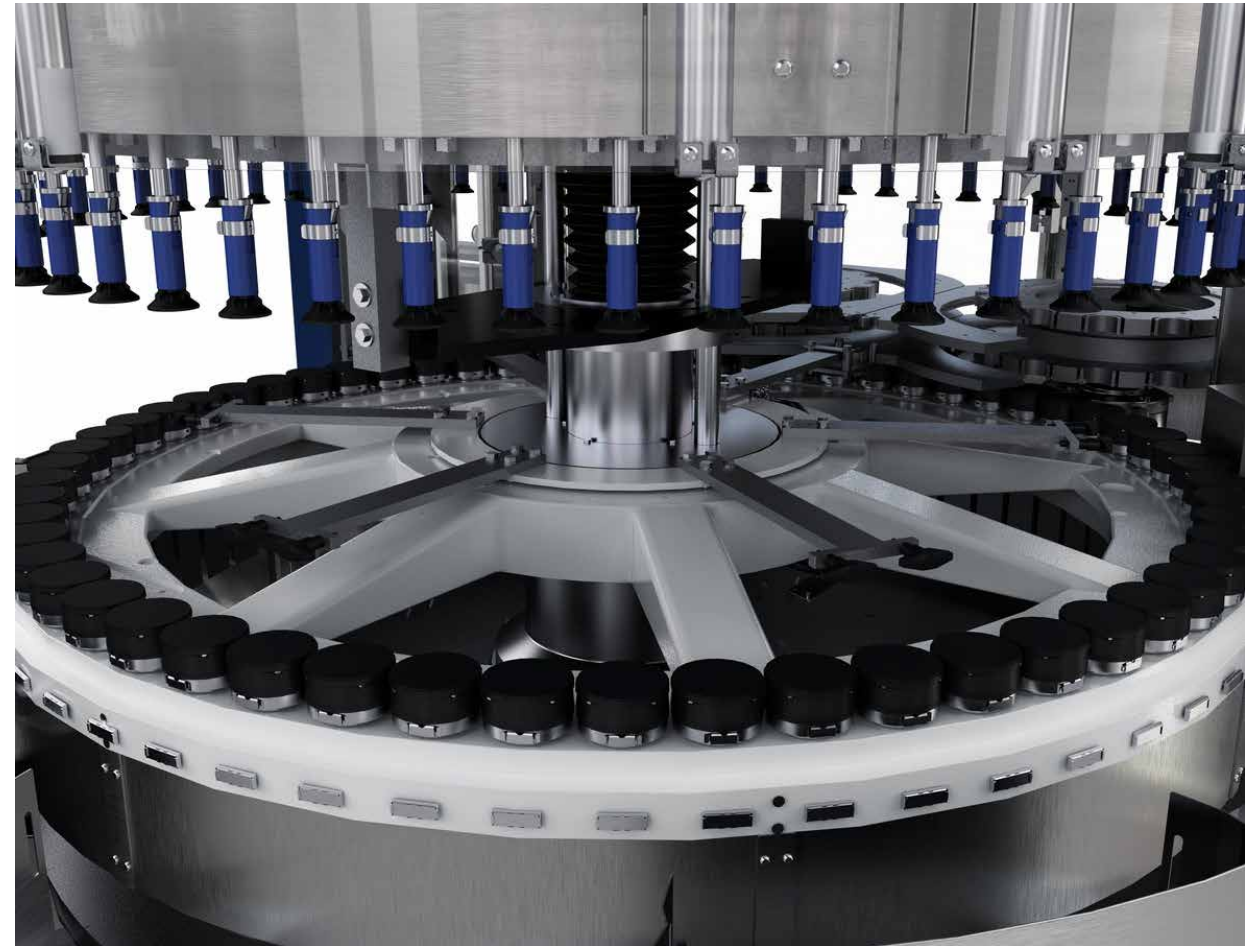

Labelling stations

Technical features



- Changeable labelling stations
- Connection according to the "plug-and-label" principle
- Automatic connection of the supply lines for air, water, power and data
- Integrated motorised height adjustment system
- Version in hygienic design

Benefits to you

- Maximum flexibility: all labelling methods possible on one and the same machine
- Short change-over times
- Elimination of operating faults
- Optimal cleaning properties
- No handling parts required for the height adjustment



Labelling stations

All versions at a glance



Ergomatic Pre-cut labels with cold glue



Contiroll Reel-fed labels with hotmelt



Canmatic Pre-cut labels with hotmelt



Autocol Reel-fed, self- adhesive labels

CL



CL DUAL



CL: Classic

- For the low to the medium output range
- Low investment costs
- Combination of well-proven Krones technology and new developments

TS: Top Speed

- For the high output range
- Advanced functions
- Top flexibility

Can be combined
with all main machines

Ergomatic CL

Labelling station for pre-cut labels with cold glue



Technical features and benefits

- Hygienic design
 - Optimal cleaning properties
- Polygon holders for glue roller, pallets and gripper cylinders
 - High-precision labelling
- All parameters saved in the operator program
 - Exactly reproducible settings

Options

- Stainless steel labelling housing
- Automatic magazine loading system



Contiroll TS

Labelling stations for reel-fed labelling with hotmelt – high output range



Technical features and benefits

- Hygienic design
 - Optimal cleaning properties
- Light-weight vacuum-grip cylinder
- Optimum accessibility
- Reduced change-over time by up to 20 percent
- Newly developed gluing unit
 - Absolute control over the glue application
 - Reduced heat-up phase by up to 20 percent
 - Reduced energy consumption by up to 15 percent
- Automatic reel splicing unit
- Electronic cutting unit
 - Guaranteed cutter replacement not required earlier than after 120 million cuts
 - Necessary time for cutter replacement: 1 minute – without service personnel
- Overlap correction possible during production

Options

- Unit for the detection of splicing points
- Antistatic equipment
- Label extraction
- Glue fume extraction system



Canmatic CL

Labelling station for pre-cut labels with hotmelt



Technical features and benefits

- Overlap correction possible during production
- Robust technology for leading-edge gluing and trailing-edge gluing
 - Output: up to 72,000 containers per hour

Option

- Hotmelt spraying system
 - Contact-free glue application
 - Closed gluing system
 - Glue consumption reduced by 50 percent



Autocol CL

Labelling stations for self-adhesive labelling – low and medium output range



Technical features and benefits

- Outputs of up to 60 meters per minute
- Operation without any pneumatic components
 - Reduced consumption costs
- Ultrasonic sensor independent from the materials
 - Precise label position
- Four-axes adjustment
- Adjustment indicators for all installation possibilities
- Simple film guidance and driven roller
- Hybrid roller technology for supplying the label film
 - Flexible applications for thick, thin and multi-layered labels
 - Compact design
 - Best accessibility
 - Ideally suited as an additional labelling station

Option

AUTO-change: DUAL variant with both applicators on one modular labelling station



Autocol CL

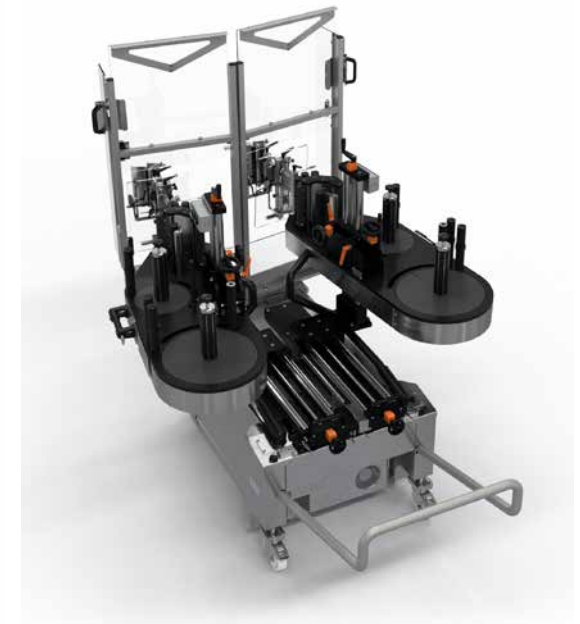

Autocol CL DUAL

Autocol TS

Labelling stations for self-adhesive labelling – high output range



Technical features and benefits

- Outputs of up to 200 meters per minute
- Ultrasonic sensor independent from the materials
 - Precise label position
- Four-axes adjustment
- Adjustment indicators for all installation possibilities
- All parameters integrated in the central operator touch-screen program
 - Easy reproducibility of the adjustments
- Feed and tension roller technology with contact-free label buffer system
 - Highest precisions at the application wedge
 - Processing of even ultra-thin labels
- Two reel holders
 - Highest operating comfort

Options

- Automatic splicing
- Five/six-axis adjustment
- Separately driven rewinder



Benefits to you



Custom-fit technology

The Ergomodul can be equipped with various labelling techniques, labelling station types and optional packages. Simply pick your suitable elements and create your individual machine.

Technology from a single source

Everything fits together here: Right from the start, the complete EM series was designed as a homogeneous product series. Disregarding of how you will configure your machine – the individual components will always seamlessly fit into each other and push each other to the highest performance.

Efficiency as a red thread

How can you perform a lot with little input? The new Krones labellers will show you exactly how that works. Regardless of whether talking about the spare parts management, the footprint, the operator effort or the energy consumption: This complex series has been designed for the maximum efficiency up to the smallest detail.

Investment for the future

The EM series comprises all the know-how of more than 70 years of Krones development. The result? An advanced machine series which particularly provides you with the following: the certainty to be equipped for any challenge of the future.

Request new machine

You can easily send a request for a non-binding quotation in our Krones.shop. 

Linadry

Container dryer for a clean labelling result



Technical features

- Stainless steel design
- Frequency-controlled blower
- Integration of visualisation system, controller and monitoring system in the labeller
- Noise level: Max. 83 dB
- Option: Automatic cleaning

Benefits to you

- Rigid construction
- Reduced energy consumption
- Easy handling
- Noise reduction



Checkmat

Inspector for every application



Technical features

- Different inspection options such as
 - Label presence
 - Detection of the splicing point
 - Excessively high labels
 - Others
- Automatic rejection of faulty containers
- Extensive statistics
- No manual adjustment required for different containers

Benefits to you

- Individual inspector configuration
- Reliability for your production
- Reduced workload for operators

Dating device

- Designed as ink-jet coding/dating device or laser printer
- Signal exchange with base machine
- Already set up in the Krones factory



Professional assistance around the clock



Remote maintenance is performed on the Ergomodul via the GRS (Global Remote Service) remote service platform. If required, a Krones expert accesses the machine via a safe internet connection in order to, for example,

- optimise your settings.
- set up new container and label types.
- train the production/operator staff.

Benefits to you

- Available at any time
 - 24 hours a day, and 7 days a week
- Cost savings
 - No travel time, immediate access
- Maximum safety
 - Establishment of connection only possible by the customer



Certified ecological efficiency

Machines with enviro seal



At Krones, the enviro label stands for excellent ecological efficiency. Products that bear the enviro label have proven in an objective test procedure that they efficiently use energy and media, and that they produce in an environmentally-friendly way. The requirements are defined by the EME standard that has been developed by the TÜV SÜD (technical inspection authority) for assessing production plants. The enviro test procedure, too, has been certified by TÜV SÜD as an independent expert. Therefore, you can be sure that: an enviro label stands for ecological efficiency.

This is why the Ergomodul is enviro-classified:

- Use of servo motors of the efficiency class IE4 or similar
- No drive train lubrication required
- Always use of food-grade lubricants
- Media measuring package and optional energy measuring package
- Significantly reduced noise level
- Safety standards according to the Machinery Directive 2006/42 EG
- Consideration of the 2006/95/EG and EU-EMV Directives (2004/108/EG)
- Design according to:
 - EN ISO 12100
 - EN ISO 13849-1
 - EN 60204-1
 - EN 61000-6-2
 - EN 61000-6-4
 - EN 13849
 - EN 62061



Everything from a single source



KIC Krones adhesives – the all-rounder for a strong grip

Regardless if PET or glass, plastic or paper, labels or packagings – at KIC Krones, you will find your ideal adhesives for a high-quality product presentation.

KIC Krones cleaning agents make your machine shine

Only if the production environment is immaculate, can your product be brilliant. KIC Krones provides you with the optimum cleaning agents and disinfectants for each individual production step.

KIC Krones lubricants for each production step

Whether for gears, chains or central lubrication systems – our greases and oils are true all-round talents. They can reach every lubrication point, protect your line and ensure gentle treatment for your products thanks to their food-grade quality.

Krones Lifecycle Service – Partner for Performance

It goes without saying that also after the purchase of new machines, Krones takes care of your lines: The Krones LCS experts are always there to help you reaching your goals and turn your wishes into optimal LCS solutions.



**SOLUTIONS
BEYOND
TOMORROW**

