

Pressant Duplex 2NT

Palletising and depalletising system in lines for returnables

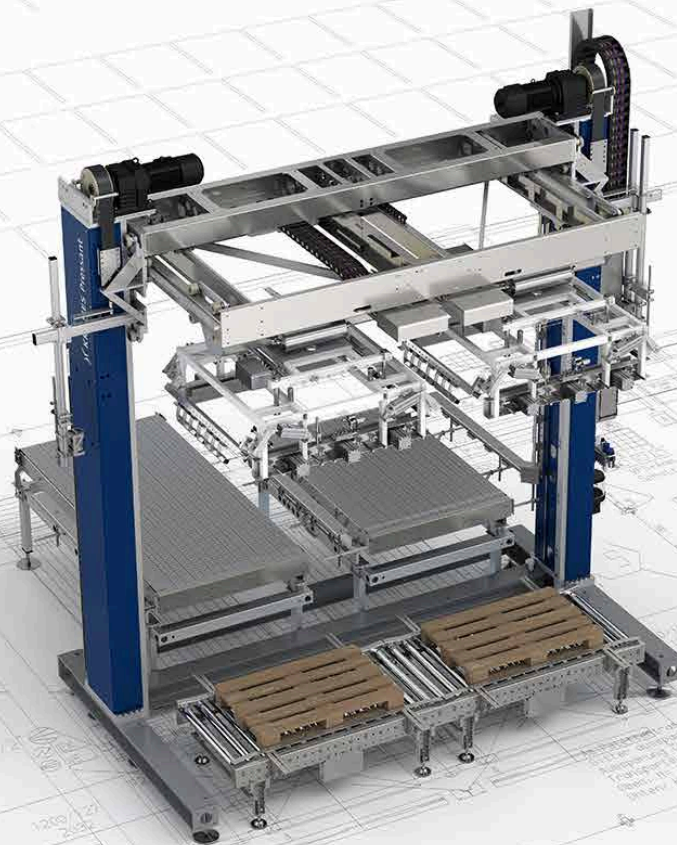

 **KRONES**

A secure grip on returnable crates



Speed is the aim when depalletising pallets containing crates with empties, but even so, layers should be grouped and full-container crates palletised reliably and at a high output. The Pressant Duplex 2NT solves both tasks with expertise. In addition to the individual design for the respective product and line configuration, it is primarily characterised by its ability to master a gentle gripping process specifically for plastic crates.

At a glance

- Palletising and depalletising of plastic crates
- Output: Up to 840 layers per hour – depending on the design
- Gentle handling of plastic crates with jaw gripper head or hook gripper head



Method of operation



The Pressant Duplex 2NT palletiser is mainly designed for the high output range thanks to its use of two palletising or depalletising stations. This machine is also equipped with two lifting columns and stands out for its high load capacity.

- In the Pressant Duplex 2NT palletiser, the packs are firstly pre-grouped in layers in two grouping stations.
- The gripper heads lift up the layers.
- Then, a telescopic transverse travel station moves the layers to the prepared pallet and sets them down.
- Designed as a depalletiser, the Pressant Duplex 2NT simultaneously lifts one layer from the each of the two pallets and sets it down on the pack discharge tables.

2NT = 2 pallet positions, level balancing, telescope

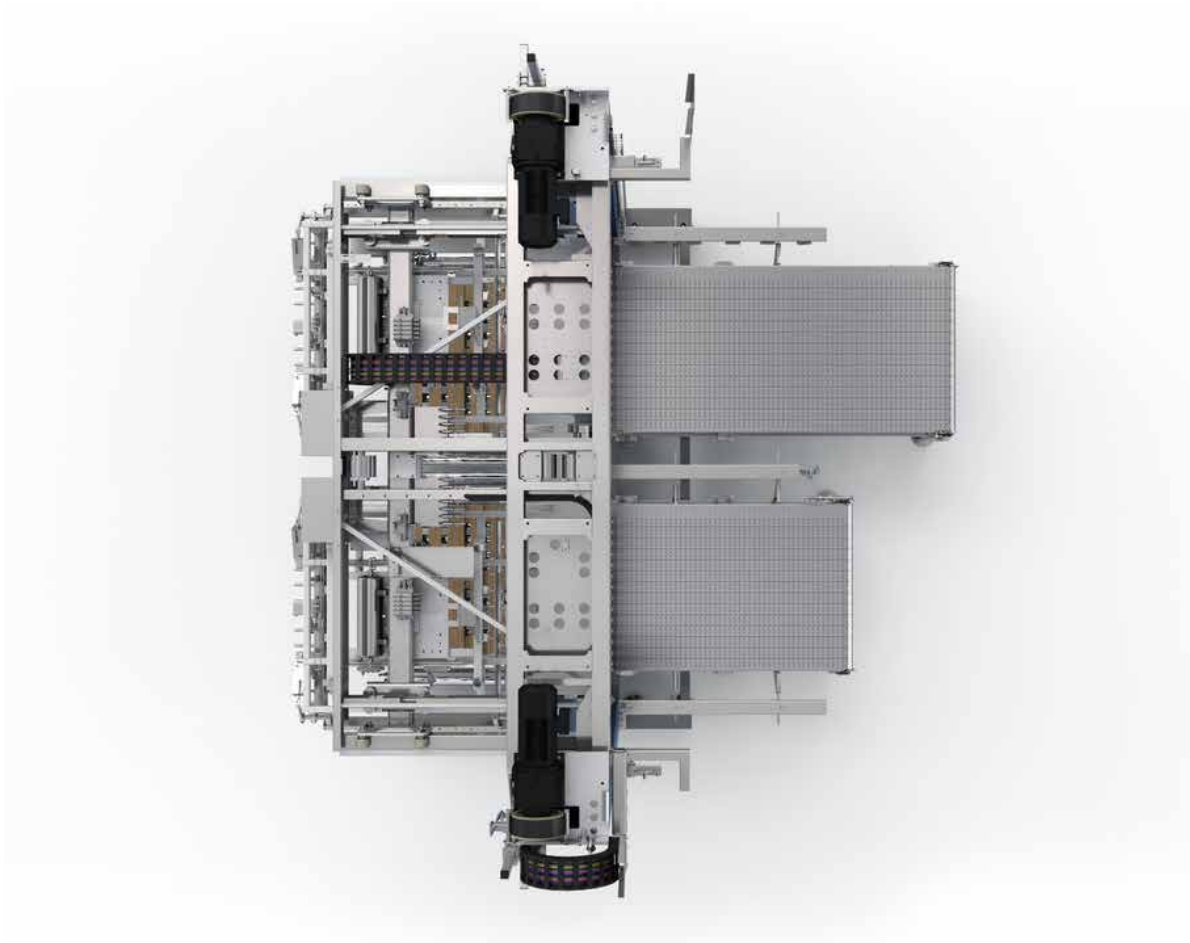

Technical details



Design features

- Modular design
- Lifting unit and telescopic transverse travel station driven by frequency-controlled or servo driven motors and maintenance-free toothed belts
- Integrated safety stop feature
- Stand-alone main operating station with Connected HMI
- Fence guarding and sliding door as protection for the operator
- Drop protection for the lifting unit protects persons when entering the safety zone

Additional equipment

- Central lubrication system

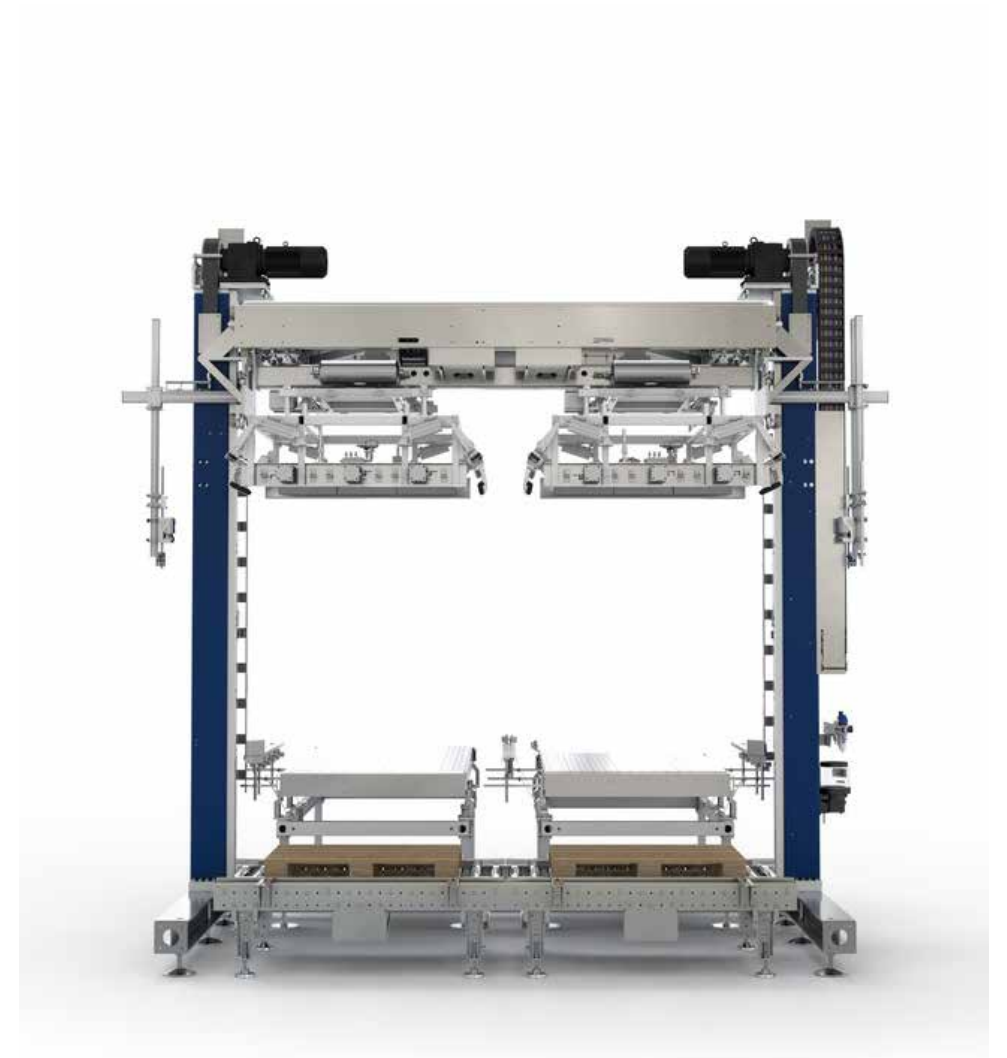

Pack handling



Lifting unit

In the Pressant series, two columns with lifting unit and a telescopic transverse travel station are used.

Grouping station or pack discharge table

Depending on the application with either a single-lane or double-lane concept, the pack supply or removal can be designed in rectangular or linear design.

Gripper head

Gripper systems for taking on the packs from the grouping station or the pallet are employed and grip the layer from all four sides for gentle transportation.

Model	Output (layers/h)*
Depalletiser	840
Palletiser	740

* Performance specifications depend on the gripper head type

Two types of gripper heads

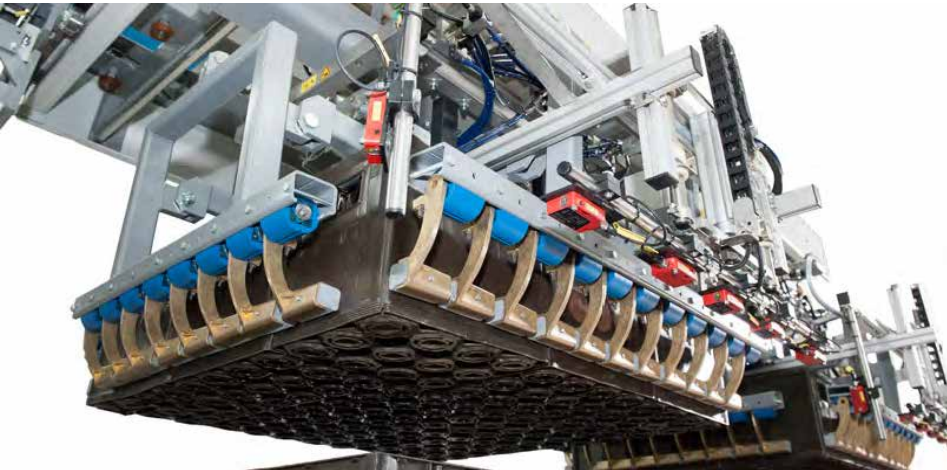

Jaw gripper head

- Secure gripping of the entire layer from all four sides
- Clamping bars designed as uninterrupted bars or as single spring-supported clamping elements

Optional:

Processing full crates is supported by hooking into the window

Hook gripper head

- Gripping of the full crates via a hook system
- Crates lock securely into place during loading thanks to an embracing centring unit
- For handling a variety of layer patterns: Optional multi-hook system available

Grouping (palletiser)



90° returnable pack grouping station

- Design conceived especially for handling crates
- Layer formation without spacing devices with steel chain infeed and servo-driven infeed control
- Easy change-over to a new program possible
- Only available with external (MultiCo) turning devices, (internal rotation not possible)

90° universal roller grouping station

- Pneumatic turning unit
- Spacing device from below
- Motor-driven centring device
- One or two-lane (can also be used for non-returnable packs)

Layer separation (depalletiser)



Layer separation with stopper bridge

- For processing column-palletised crates in a linear arrangement
- Layer separation from top with stopper bridge
- Continuous discharge of the rows after stopper engagement from above
- Pack row separation in high performance range

Layer separation with separation roller

- Separation of interlocked layer patterns
- Separation of the first row of one layer by means of acceleration with separation roller
- Subsequent discharge in a 90 degree angle

Layer separation with drawing mechanism

- Separation of interlocked layer patterns
- Separation of layers using a drawing mechanism
- Row separation to the front, where it is transported away at a 90 degree angle using carriers that enter from above

Benefits to you



High performance

The duplex design makes it possible to palletise or depalletise two pallets in one cycle.

High positioning accuracy

Precise gripping technology and finely tuned lifting unit transfer motions ensure precise movement sequences during palletising and depalletising – and therefore high speeds for returnable packs.

Economic continuous operation

Durable assemblies and components guarantee the highest reliability and high system accessibility – even in continuous operation mode.

Ease of operation

The well-arranged structure of all functions on the touch-screen allows for quick handling of all operating tasks.

Variable line layout

The grouping station and the discharge table can be arranged at a 90 degree angle. This way, the palletising system is perfectly suited to all line layouts.

Requesting a new machine

You can easily send a request for a non-binding quotation in our Krones.shop.



Everything from a single source



Training sessions at the Krones Academy – trained personnel for an increased efficiency of your line

The multifaceted offer by the Krones Academy ranges from operation, servicing and maintenance courses through to management training. We will gladly also create your individual training programme.

Krones Lifecycle Service – Partner for Performance

It goes without saying that also after the purchase of new machines, Krones takes care of your lines: The Krones LCS experts are always there to help you reaching your goals and turn your wishes into optimal LCS solutions.

KIC Krones cleaning agents make your machine shine

Only if the production environment is immaculate, can your product be brilliant. KIC Krones provides you with the optimum cleaning agents and disinfectants for each individual production step.



**SOLUTIONS
BEYOND
TOMORROW**

