

# Sleevematic TS

Faster sleeving than ever before



## Turbo in stead of cycles

No machine has ever managed this before: The Sleeveomatic TS sleeves up to 50,000 container per hour with just one labelling station! What's its secret? It uses a completely new cutting method. Unlike at other machines, the Sleeveomatic TS cuts the sleeves in an ongoing movement and not in cycles with a stop-and-go operation.

### At a glance

- It sleeves up to 50,000 containers per hour with only one labelling station
- It applies sleeves with micro perforation
- It employs rotating perforating blades
- It works continuously without any cycles





## Machine structure

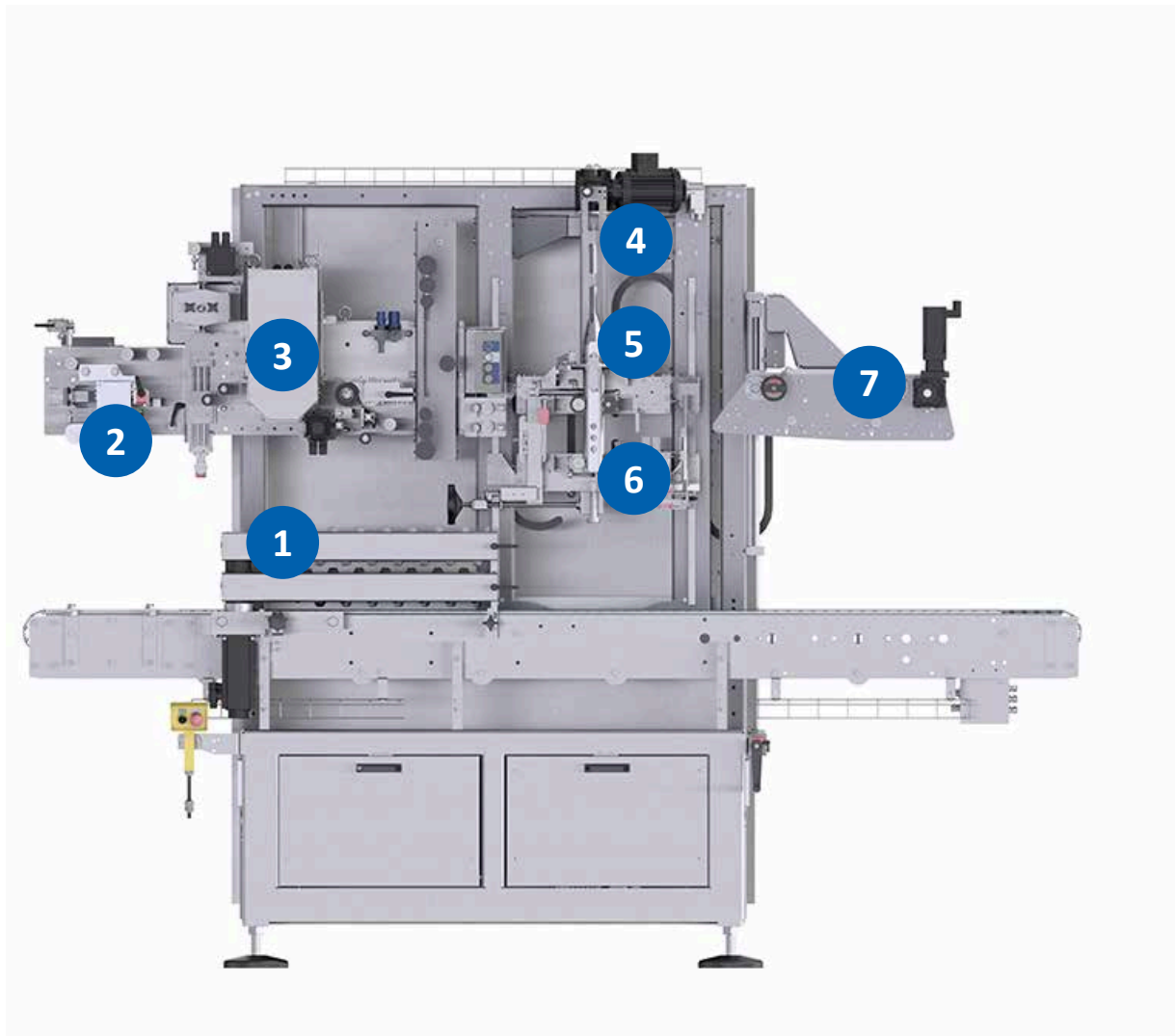

1. Container infeed with servo-motor-driven infeed worm
2. Label web guider
3. Perforation unit with register mark controller
4. Mandrel for opening the sleeves
5. Servo-motor-driven feed roller
6. Servo-motor-driven transfer roller for separating the sleeve sections
7. Sleeve positioning unit

*No more stop-and-go: Due to the omission of the cutting cycle, the sleeve film can be continuously conveyed and the sleeve performance increased by up to 70 percent.*



## Direct comparison of the conventional technology versus the Sleeveomatic TS

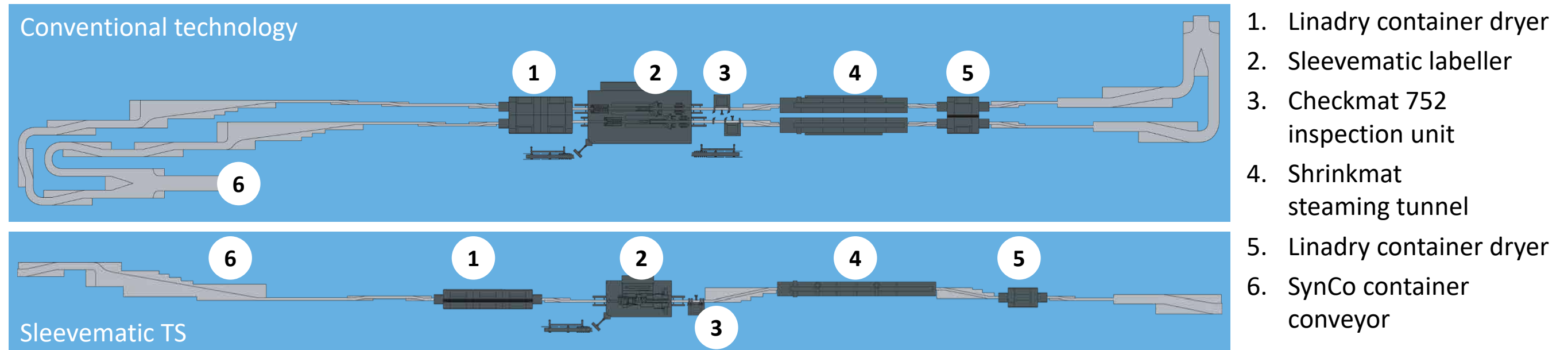

One machine – many effects: In comparison to the traditional sleeve labelling, this sleeve labeller requires:

- 1 conveyor less
- 1 steaming tunnel less
- 2 dryers less
- 1 inspection unit less

and

- up to 40 percent less power
- up to 50 percent less compressed air
- up to 25 percent less steam

The TS achieves **significant savings** at:

- Investment costs
- Footprint
- Energy costs
- Maintenance costs





## Everything put in mind

The Sleeveomatic TS has been developed from the field experiences for the field. This appears in many technical details which facilitate the daily production routine significantly.

### Main machine

- At the push of a button, the contact pressure of the feed rollers is adjusted via pneumatic cylinders.
- Sleeve conveyance is performed without slippage via servo-motor-driven rollers.
- The perforating blades can be exchanged within two minutes.
- An integrated climbing aid enables the operator the ergonomic replacement of handling parts.
- The infeed worms are stored directly in the machine and are therefore ready for use at any time.

### Sleeve buffer system

- Stand-alone and individual positions
- Capacity for two sleeve rollers with a total of approx. 4,000 m of sleeve
- Manual splicing of the end of the reels without any machine standstill thanks to a buffer of approx. 45 m





## Optional components

### Linadry dryer

- High-quality stainless steel version
- Up to 20 percent savings of energy via frequency-controlled blowers with a consumption of 11 kW
- Visualisation system, control and monitoring via the Sleeveomatic TS touch-screen
- Noise-reduced operation with maximally 83 dB
- Optional automatic cleaning system



### Multireel label supply unit

- Keeps six or eight film reels in storage
- Operates up to eight hours without any operator interference
- Enables film reel splicing at a nominal output of the Sleeveomatic





## Optional components

### Shrinkmat steaming tunnel

- Thanks to its modular design, it can also be expanded at a later point
- Thanks to its adjustable nozzles bars, it ensures a reproducible shrinking result
- Prepared for a quick installation for the connection to a steam supply system provided by the customer
- Can be equipped with transparent doors for a better view into the machine

### Checkmat inspector

- Individual selection of the inspection performances, e.g. splicing point detection, sleeve position, etc.
- High production safety thanks to automatic rejection of faulty containers
- Transparent production due to comprehensive inspection statistics
- Inspection of different containers without manual adjustment
- Automatic data exchange with the Sleeveomatic TS

### Coding/dating device

- Available as an ink-jet coding/dating device or laser printer
- Prepared for signal exchange with the Sleeveomatic TS already before the delivery







## Optional components

### Spraying system

- Increases the gliding properties of the sleeves on the bottle
- Compensates deviations of the material properties of the bottles

### Remote service

Professional assistance around the clock: With the remote service platform GRS (Global Remote Service), a KRONES expert can log on to your machine via a safe internet connection, in order to e.g.:

- optimise your settings.
- adjust a new type.
- train the production/operator staff.







## Your benefits in figures

Thanks to rotary cutters which perforate the film sleeve continuously in stead of in cycles, the Sleeveomatic TS can process **50,000 containers per hour**.

A set of perforation cutters can perform **70 million cuts** before it wears out. Conventional cutting units can only master a tenth of this.

The change-over of the perforating blade takes **2 minutes**.

**0 handling parts change-overs** are required for changing over to other sleeve widths. Owing to the fact, that the rotating perforation cutters are operating regardless of the format, the Sleeveomatic TS requires significantly less handling parts than all other sleeving systems.





## Everything from a single source

### **Training sessions at the KRONES Academy – trained personnel increases your line efficiency**

The versatile training offer ranges from operation, servicing and maintenance to management training. We will gladly also establish your individual training programme.

### **KRONES Lifecycle Service – partner for performance**

Also after having purchased a new machine, KRONES will take care of your line; the LCS experts are always ready to consult you and translate your goals and wishes into optimal LCS solutions.

### **KIC KRONES adhesives – the all-rounder for a strong grip**

Regardless if PET or glass, plastic or paper, labels or packagings – at KIC KRONES, you will find your ideal adhesives for a high-quality product presentation.

### **KIC KRONES cleaning agents make your machine shine**

Only if the production environment is immaculate, can your product be brilliant. KIC KRONES provides you with the optimum cleaning agents and disinfectants for each individual production step.

### **Lubricants from KIC KRONES for every production step**

Whether for gears, chains or central lubrication systems – our greases and oils are true all-round talents. You can reach every lubrication point, protect your line and provide gentle treatment for your product thanks to our products' suitability for food.





Digitalisation



Process  
technology



Bottling and  
packaging equipment



Intralogistics



Lifecycle  
Service

We do more.

 **KRONES**